



6+



4



2,32m



1 = 2,46m
2 = 1,04m
3 = 3,01m

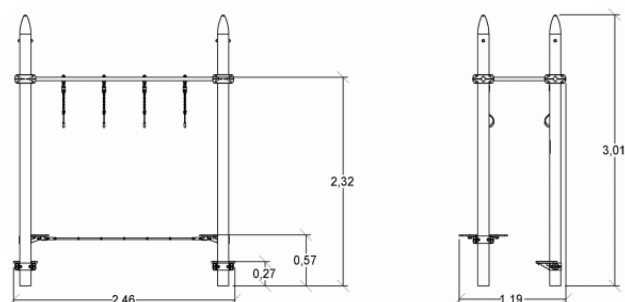

Funciones Lúdicas : 6

equilibrarse



x1

atravesar



x3

colgarse



x2

Instalación del equipamiento

IMPORTANTE: Es imprescindible consultar las instrucciones de montaje para conocer las dimensiones de las zonas de s

———— Zona de impacto (superficie mínima normativa)

- - - - Espacio libre

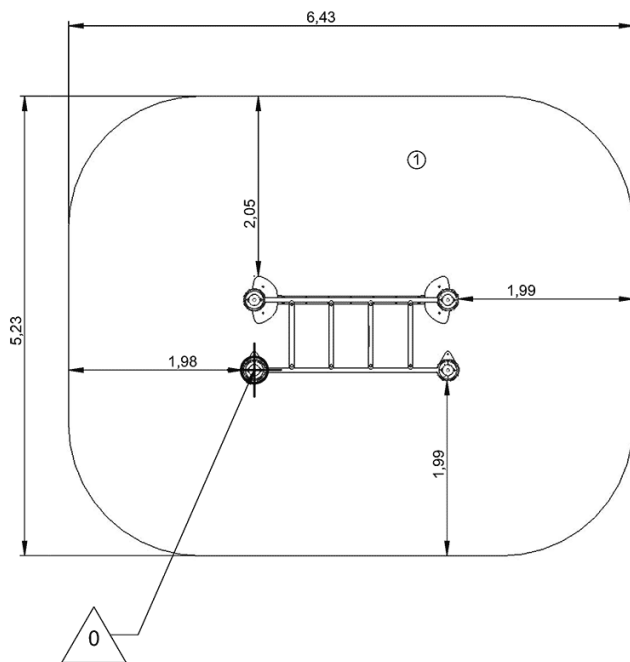

1	2,32m	32m ²



2



02h00



0.26m³



32m²



157kg



25kg

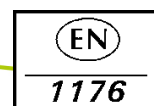

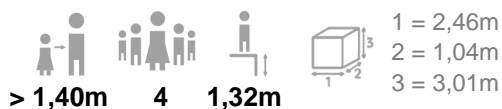

Ecuación deportiva

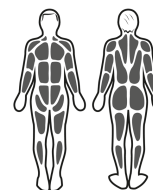

Estimulación muscular

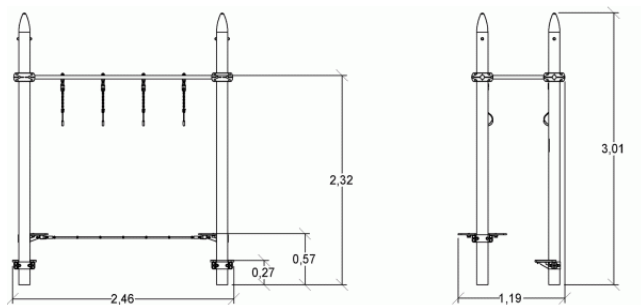

► **Actividades deportivas : 6**

equilibrarse



atravesar



colgarse



refuerzo muscular

cardio

equilibrio

coordinación



► Instalación del equipamiento

IMPORTANTE: Es imprescindible consultar las instrucciones de montaje para conocer las dimensiones de las zonas de s

— Zona de impacto (superficie mínima normativa)

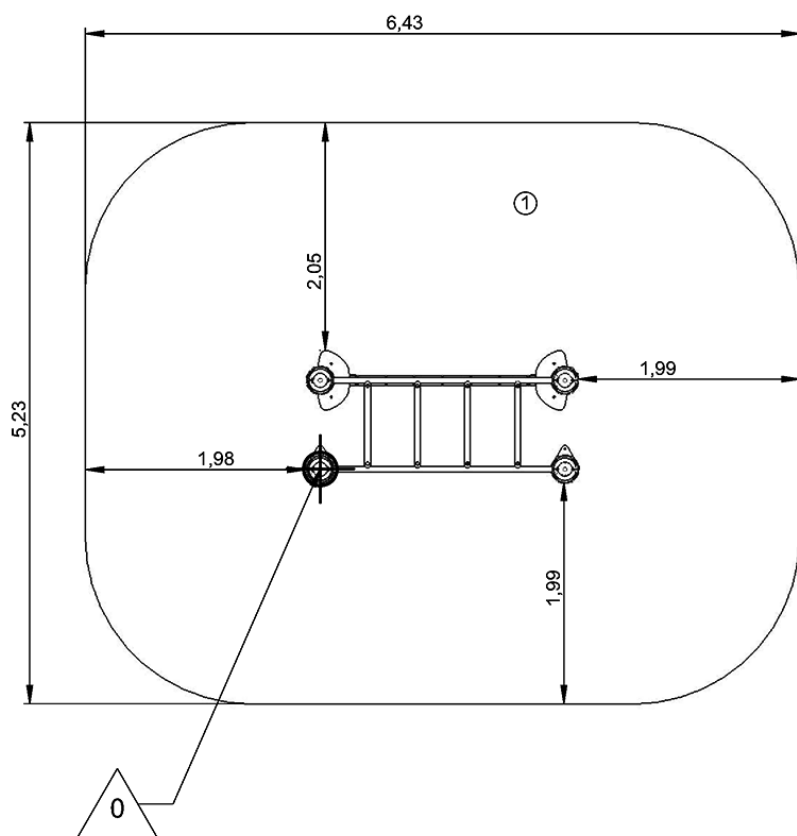
— — Espacio libre



		
1	1,32m	21m²



2



02h00



0.26m³



32m²



157kg



25kg

