



14+



2



2,4m



1 = 2,4m
2 = 0,65m
3 = 2,51m

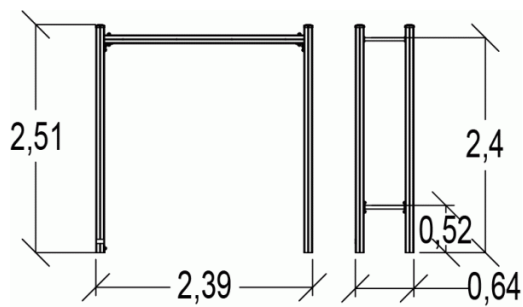

Funciones Lúdicas : 3

atravesar



x1

colgarse



x1

Tracción



x1

Instalación del equipamiento

IMPORTANTE: Es imprescindible consultar las instrucciones de montaje para conocer las dimensiones de las zonas de s

— Zona de impacto (superficie mínima normativa)

- - - Espacio libre

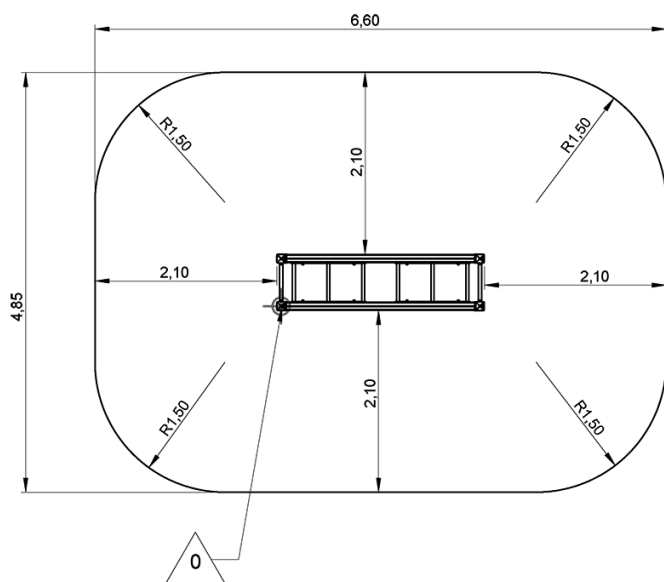

1	2,4m	30m ²



2



01h45



0.1m³



18m²



133kg



20kg

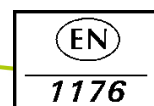



Ecuación deportiva

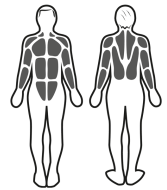

Estimulación muscular



Movimientos

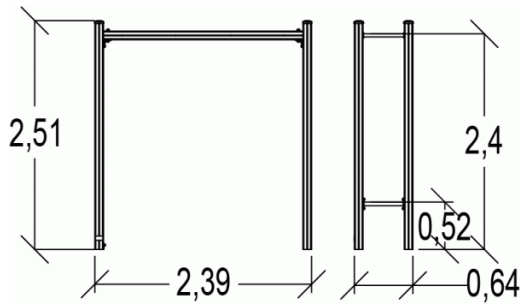

► **Actividades deportivas : 3**

atravesar



colgarse



Tracción



refuerzo muscular

cardio

equilibrio

coordinación

► Instalación del equipamiento

IMPORTANTE: Es imprescindible consultar las instrucciones de montaje para conocer las dimensiones de las zonas de s

— Zona de impacto (superficie mínima normativa)

— — — Espacio libre

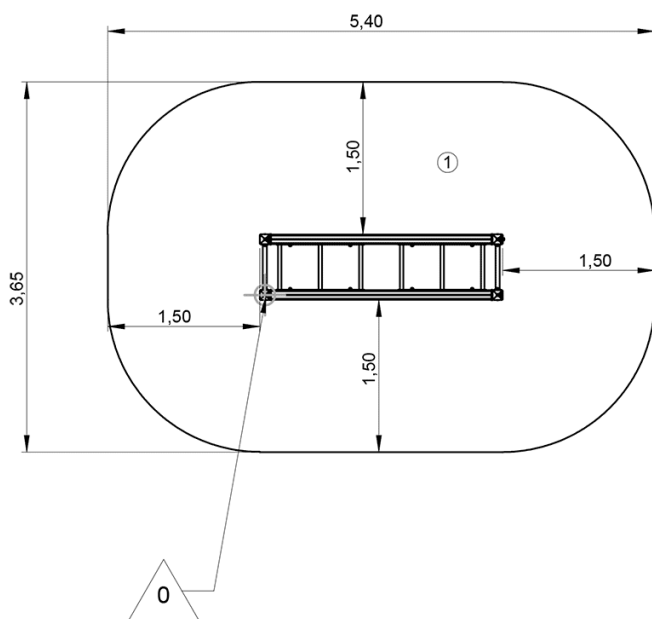

1	1,4m	18m ²



2



01h45



0.1m³



18m²



133kg



20kg

